

# SMART3G-D2

with catalytic sensor

The SMART3G-D2 gas detector is designed to meet industrial requirements; the enclosure is explosion proof and can be installed in ATEX Zone 1 and, when equipped with dust adapter, in Zone 21.

The sensing element is housed in the stainless steel head. The pellistor sensors employed for the flammable gas detection show an excellent output linearity up to 100% LEL and fast time of response.

The gas detector has a 12-24 Vdc power supply and a standard 4-20 mA 3-wires output and three relays. Optionally, the SMART3G-D2 can be equipped with serial RS485 communication.

The aluminium enclosure has dimensions 145 x 187 x 108 mm. The enclosure has 3 cable entries 3/4" NPT threaded. The SMART3G-D2 features a 7-segment display for real-time concentration visualization and Hall effect sensors for non-intrusive field calibration.

The gas detector can be ATEX marked as follows:

CE 0722 Ex II 2G Ex db IIC T5 Gb

Or, when equipped with dust adapter:

CE 0722 Ex II 2GD Ex db IIC T5 Gb  
Ex tb IIIC T5 T100°C Db  
IP65

The gas detector is IECEx complaint and can be marked as follows:

II 2G Ex db IIC T5 Gb

Or, when equipped with dust adapter:

II 2GD Ex db IIC T5 Gb  
Ex tb IIIC T5 T100°C Db  
IP65

SMART3G-D2 is SIL2 hardware and SIL3 software; with a redundant system also the hardware is SIL3.



Sensor	
Application	Industrial area, ATEX Zone 1 and Zone 21 (when equipped with dust adapter, optional)
Sensing element	Catalytic
Predicted sensor lifetime	4 / 5 years
Gas detected	Flammable gas
Fullscale	0 - 100% LFL
Electrical data	
Power supply	12-24 Vdc
Output	Analogue 4-20 mA output; 3 relay board; serial RS485 output (optional)
Maximum dissipated power	5.4 W
Relays contact ratings	1.0 A at 30 Vdc
Optical indications	7-segment display, 5 status LED and 4 intelligent LED
Acoustic indications	-
Hall effect sensor	Three sensors for calibration by magnet
Environmental conditions	
Storage temperature	-40 / +85°C
Operating temperature	-40 / +60°C *
Operating humidity	20 / 90% RH @40°C *
Operating pressure	80 / 120 kPa *
Air velocity	6 m/s *
Time of response	t <sub>90</sub> < 60 s ; t <sub>50</sub> < 20 s *

\* Data tested with tests described in EN 60079-29-1 standard

External case	
Material	Enclosure: aluminium pressure die-casting with epoxy paint chromating and chemically resistant Sensor head: stainless steel
Protection mode	Ex d : Explosion proof enclosure Ex t : Equipment dust ignition protection by enclosure (when equipped with dust adapter, optional)
Dimensions	145 x 187 x 128 mm
Weight	1900 g
Cable entries	3 x 3/4" NPT
IP grade	IP65
Compliance	
EMC	EN 61000-6-3:2007 + A1:2011; EN 50270:2015
ATEX	ATEX directive 2014/34/UE EN IEC 60079-0:2018 EN 60079-1:2014 EN 60079-31:2014 EN 60079-29-1:2016
IECEX	IEC 60079-0:2011 IEC 60079-1:2014 IEC 60079-31:2013
SIL	EN 61508:2010 Parts 1, 2, 3, 4, 5, 6, 7 EN50402:2017

# SMART3G-D2

with catalytic sensor

## Product codes

## ATEX code

S2157ME	METHANE detector	ST / LW / E3 / S3	S2157ES	HEXANE detector	ST / LW / E3 / S3
S2157GP	LPG detector	ST / LW / E3 / S3	S2157H2	HYDROGEN detector	ST / LW / E3 / S3
S2157BU	BUTANE detector	ST / LW / E3 / S3	S2157IB	ISO BUTANE detector	ST / LW / E3 / S3
S2157PR	PROPANE detector	ST / LW / E3 / S3	S2157IT	ISO BUTYL ALCOHOL detector	ST / LW / E3 / S3
S2157VB	PETROL VAPOURS detector	ST / LW / E3 / S3	S2157IN	ISO PENTANE detector	ST / LW / E3 / S3
S2157AA	ACETIC ACID detector	ST / LW / E3 / S3	S2157IP	ISO PROPYL ALCOHOL detector	ST / LW / E3 / S3
S2157AT	ACETONE detector	ST / LW / E3 / S3	S2508P8	JP8 detector detector	ST / LW / E3 / S3
S2179AC	ACETYLENE detector	ST / LW / E3 / S3	S2157MT	METHYL ALCOHOL detector	ST / LW / E3 / S3
S2157AM	AMMONIA detector	ST / LW / E3 / S3	S2157MK	METHYL ETHYL KETONE (MEK) detector	ST / LW / E3 / S3
S2157BZ	BENZENE detector	ST / LW / E3 / S3	S2157NN	NONANE detector	ST / LW / E3 / S3
S2157CE	CYCLOHEXANE detector	ST / LW / E3 / S3	S2157PE	PENTANE detector	ST / LW / E3 / S3
S2157CP	CYCLOPENTANE detector	ST / LW / E3 / S3	S2157PP	PROPYLENE detector	ST / LW / E3 / S3
S2157EN	ETHANE detector	ST / LW / E3 / S3	S2157PN	PROPYL ALCOHOL detector	ST / LW / E3 / S3
S2157AE	ETHYL ACETATE detector	ST / LW / E3 / S3	S2157ST	STYRENE detector	ST / LW / E3 / S3
S2157ET	ETHYL ALCOHOL detector	ST / LW / E3 / S3	S2157TM	TRI-METHYLBENZENE detector	ST / LW / E3 / S3
S2157EE	ETHYL ETHER detector	ST / LW / E3 / S3	S2157TO	TOLUENE detector	ST / LW / E3 / S3
S2157EL	ETHYLENE detector	ST / LW / E3 / S3	S2157AV	VINYL ACETATE detector	ST / LW / E3 / S3
S2157OE	ETHYLENE OXIDE (ETO) detector	ST / LW / E3 / S3	S2157XI	XYLENE detector	ST / LW / E3 / S3
S2157EP	HEPTANE detector	ST / LW / E3 / S3			

## Mechanical drawings

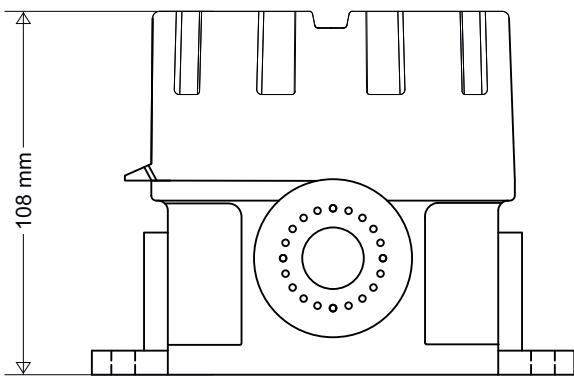

STG/AD3  
Dust adapter

