

K-Detect-iON

User Manual



Copyright:

Copyright © 2025 Kentec Electronics. All rights reserved.

Reproduction without permission is prohibited.

Trademarks:

K-Detect-iON is a licensed trademark by Kentec Electronics. All other trademarks or registered marks in this manual belong to their respective manufacturers.

Disclaimer:

Information in this document is subject to change without notice and does not represent a commitment on the part of Kentec Electronics.

Kentec Electronics provides this document "as is," without warranty of any kind, either expressed or implied, including, but not limited to, its particular purpose. Kentec Electronics reserves the right to make improvements and/or changes to this manual, or to the products and/or the programs described in this manual, at any time.

Kentec Electronics has made this document to the best of its abilities. However Kentec Electronics assumes no responsibility for its use, or for any infringements on the rights of third parties that may result from its use.

This product might include unintentional technical or typographical errors. Changes are periodically made to the information herein to correct such errors, and these changes are incorporated into new editions of the publication.

Section 1	
Introduction	1
Section 2	
All about K-Detect-iON	2
2.1 Certifications and Calibrations	2
2.2 Sensor Metrics	2
2.3 Technical Specification	2
2.4 Environmental Specification	3
2.5 Physical Specifications	3
2.6 Parts of the K-Detect-iON Sensor	3
Section 3	
System Architecture	5
Section 4	
CH₄ Gas Detection: Cross Sensitivity and Precautionary Measures	6
Section 5	
H₂ and Other Flammable Gas Detection	8
Section 6	
Implementation	9
6.1 Preparation	9
6.2 Mounting Installation Guidelines	9
Section 7	
Setting Up	11
7.1 Securing Wires in Screwless Terminal Blocks	11
7.2 Powering up the K-Detect-iON	12
7.3 Standalone RS485 Connection (Modbus)	13
7.3.1 Default Modbus Connection Settings	13
7.3.2 Default Relay Threshold	14
7.3.3 Default Relay State	14
7.3.4 Relay Delay	14
7.3.5 Relay Minimum Running Time	14
7.4 Modbus Table	15
7.5 Connecting K-Detect-iON to Fire Alarm	17
Section 8	
Testing	19
8.1 Periodic Bump Testing of Sensors	19
8.2 Bump & Calibration gases for CH ₄	20
8.3 Bump & Calibration gases for H ₂ & other flammable gas detection	20
8.4 Testing via Modbus	21

Section 1

Introduction

The K-Detect-iON sensor is an advanced, self-calibrating standalone device specifically designed to monitor flammable gas types in stationary systems. With a user-settable Slave ID offering 254 combinations and factory calibration, this sensor provides enhanced convenience and reliability.

With a recommendation of one sensor per rack for comprehensive monitoring, the K-Detect-Ion sensor is an indispensable tool for critical facilities. The sensor can be configured to detect different gases based on specific customer needs.

Listed to UL2075 and calibration free flammable gas sensor designed to detect the presence and measure the concentration of flammable gases in non-hazardous critical facilities from 0-100% LEL. Patent Pending.

Section 2

All about K-Detect-iON**2.1 Certifications and Calibrations**

ETL listed to UL 2075
IEC60068-2-30, IEC 60068-2-6, IEC 61000-4-4, IEC 61000-4-5, IEC 61000-4-6
Compliant with EMC directive (EU) 2014/30 - EN50270:2015, EN55032:2015, EN55035:2017
Compliant with Low Voltage Directive (EU) 2014/35 - EN61010:2010
REACH compliant
RoHS 3 compliant

2.2 Sensor Metrics

Internal temperature measurement range	-40°C to 125°C (-40°F to 257°F)
Internal temperature accuracy	±0.48°C (0.86°F)
Internal relative humidity measurement range	0 to 100% RH
Internal relative humidity accuracy	2% RH
VOC measurement output range	0-500 VOC Index
VOC repeatability	<±5 VOC index points or % mass volume (m.v.)
Butane (C ₄ H ₁₀) accuracy	±5% LEL
Ethane (C ₂ H ₆) accuracy	±5%LEL
Hydrogen (H ₂) accuracy	±5% LEL
Isobutane (CH ₃) accuracy	±5% LEL
Methane (CH ₄) accuracy	±5% LEL
Octane (C ₈ H ₁₈) accuracy	±12% LEL
Pentane (C ₅ H ₁₂) accuracy	±5% LEL
Propane (C ₃ H ₈) accuracy	±6% LEL
Propylene (C ₃ H ₆) accuracy	±5% LEL
Toluene (C ₇ H ₈) accuracy	±12% LEL
Xylene (C ₈ H ₁₀) accuracy	±12% LEL
Response time (T90)	<30s
Detection Range	0-100 %LEL
Detection method	Spectrometer

2.3 Technical Specification

Relay outputs	3 (Normally Open)
Relay switching current	up to 0.5A
Input Voltage	12-24V DC
Power usage	672mW
Protocol	Modbus RTU over RS485
	Integration with BASE-XX over RJ45 (serial data)
Life span	Up to +10 years

2.4 Environmental Specification

- Hydrogen (H₂)

Operating temperature range	-40°C to 75°C (-40°F to 167°F)
Humidity (operating and storage)	0 to 100% RH (non-condensing)

- Methane (CH₄)

Operating temperature range	-40°C to 70°C (-40°F to 158°F)
Humidity (operating and storage)	< 90% RH (non-condensing)

2.5 Physical Specifications

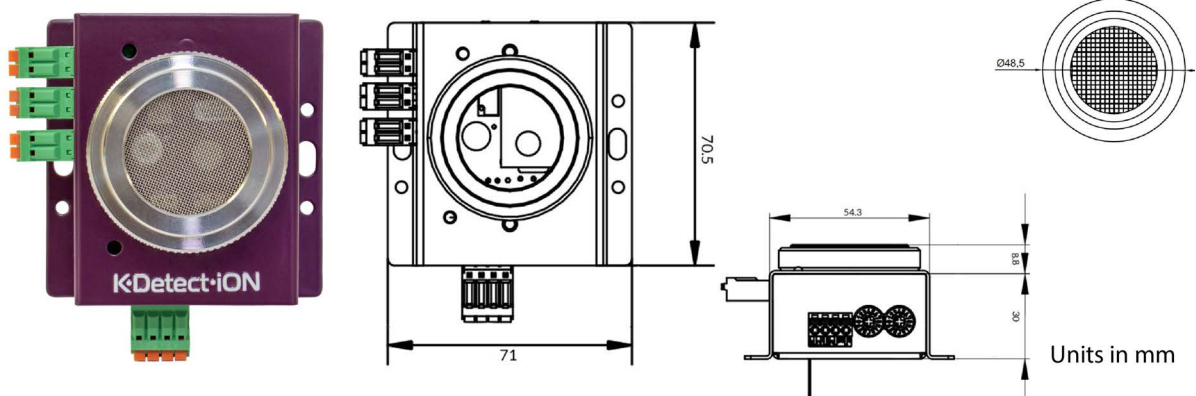

Sensor enclosure	Steel enclosure, industrial grade
Mounting option	0U rack, DIN rail or wall mountable
Dimensions	71mm (2.79") x 70.5mm (2.77") x 30 mm (1.18")
Weight	193g (0.43lb)

2.6 Parts of the K-Detect-iON Sensor

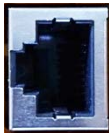

RJ45 Port - This port serves as the communication with the Base Unit (Not Used).



LED - The LED provides signals when the sensor is ready for operation and alerts when the sensor state is missing, offering users a clear and immediate overview of the sensor's operational condition.

LED Status Light:

Warning – Amber
 Down – Red
 Fault – Red
 Normal Condition – Green



Gas Cap - The gas cap serves as a protective cover for the sensor, ensuring its durability and safeguarding it from external elements.

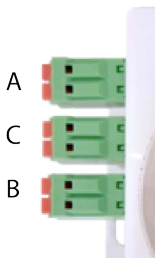

Configurable output relays -

- A – Relay A - Alarm
- C – Relay C - Fault
- B – Relay B – Alarm



Mounting hole - This allows users to mount the sensor according to their preferences, providing flexibility in installation. Please see section 6.2 for different types of mounting options.

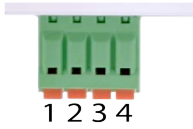

Terminal Block – This block comprises terminals for various connections :

- Terminal 1: 12 to 24V DC power input
- Terminal 2: (B-) Connection
- Terminal 3: (A+) Connection
- Terminal 4: Ground (GND)



Rotary Encoder – The rotary encoder is a user interface component that can be rotated to input or adjust settings, facilitating user interactions with the sensor's configuration. With user settable address out of 254 combinations.

Section 3

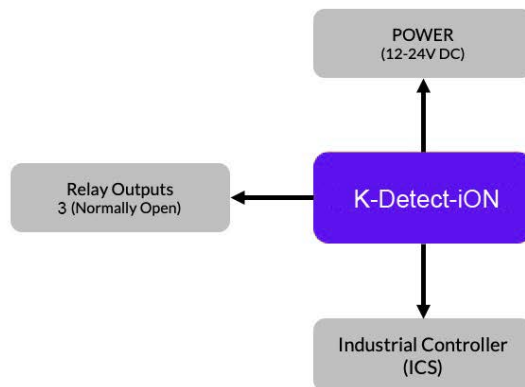
System Architecture

The core of our system architecture lies in the K-Detect-iON sensor, which operates seamlessly on a direct power supply ranging from 12 to 24V DC. This sensor, specifically designed for monitoring gas levels, serves as a critical component in our setup. The sensor is directly interfaced with an INDUSTRIAL CONTROLLER (ICS) or Modbus Controller, forming a robust connection that facilitates the transfer of real-time data and enables efficient control and monitoring within our industrial environment.

Furthermore, the K-Detect-iON sensor enhances its versatility with three normally open relays. These relay outputs contribute to the system's functionality by providing additional control capabilities. This architecture not only ensures reliable power supply and data connectivity but also equips the system with the ability to actuate external devices or processes through the integrated relay outputs, enhancing the overall efficiency and responsiveness of our industrial control setup.

Section 4

CH₄ Gas Detection: Cross Sensitivity and Precautionary Measures

Cross-sensitivity occurs when a gas sensor responds not only to its target gas but also to other gases in the environment. This characteristic is particularly important to consider when using gas detection systems in environments where multiple gases may be present.

This cross-sensitivity requires careful management to ensure accurate gas detection and system reliability.

Additionally, gas contaminants can impact the performance and longevity of sensors. Below is a list of gas contaminants that should be considered during installation and operation:

H₂S (Hydrogen Sulphide)

SO_x (Sulphur Oxides)

Cl₂ (Chlorine)

HCl (Hydrogen Chloride)

Here are the list of gases that are cross sensitive to methane (CH₄):

- Methane (CH₄)
- Hydrogen (H₂)
- Carbon Monoxide (CO)
- Propane (C₃H₈)
- Ethylene (C₂H₄)
- Ethane (C₂H₆)
- Hexane (C₆H₁₄)
- Benzene (C₆H₆)
- Toluene (C₇H₈)
- Xylene (C₆H₄)
- Ammonia (NH₃)
- Hydrogen Sulphide (H₂S)
- Acetaldehyde (C₂H₄O)
- Formaldehyde (CH₂O)
- R-22
- R-134a
- R-404A
- R-410A

To address this, specific precautions are necessary. By implementing cautions, users can ensure the sensor operates effectively, providing reliable and accurate measurements even in challenging conditions.

1. Exposure to silicone vapours - if silicone vapours absorbs onto the sensor's surface, the sensing material will be coated, irreversibly inhibiting sensitivity. Avoid exposure where silicone adhesives, hair grooming materials, or silicone rubber/putty may be present.
2. Highly corrosive environment - high density exposure to corrosive materials.
3. Contamination by alkaline metals - sensor drift may occur when the sensor is contaminated by alkaline metals, especially salt water spray.

4. Operation in zero/low oxygen environment - sensors require the presence of around 21% (ambient) oxygen in their operating environment in order to function properly. Sensors cannot properly operate in a zero or low oxygen content atmosphere.
5. Excessive exposure to alcohol - if the sensor is exposed to high concentrations of alcohol (such as 10,000 ppm or more) for a long period of time, the filter may become saturated.
6. Lighter gas exposure test - consumers often check if detectors are actually sensing gas by exposing them to lighter gas (main component is iso-butane). Because the filter will block iso-butane from reaching the sensing element, this test cannot be used with the sensor.

Section 5

H₂ and Other Flammable Gas Detection

Hydrogen (H₂) and other flammable gases pose significant safety risks in industrial and commercial settings. Reliable detection systems provide early warnings, and ensuring safety compliance. Below are the list of the flammable gases:

Butane (C ₄ H ₁₀) accuracy	±5% LEL
Ethane (C ₂ H ₆) accuracy	±5% LEL
Hydrogen (H ₂) accuracy	±5% LEL
Isobutane (CH ₃) accuracy	±5% LEL
Methane (CH ₄) accuracy	±5% LEL
Octane (C ₈ H ₁₈) accuracy	±12% LEL
Pentane (C ₅ H ₁₂) accuracy	±5% LEL
Propane (C ₃ H ₈) accuracy	±6% LEL
Propylene (C ₃ H ₆) accuracy	±5% LEL
Toluene (C ₇ H ₈) accuracy	±12% LEL
Xylene (C ₈ H ₁₀) accuracy	±12% LEL

The H₂ and other flammable gas detection is inherently immune to siloxanes and poisoning.

Section 6

Implementation

In this section, you will gain insights into the practical aspects of deploying our sensor technology. We provide detailed information on how the sensors are installed, including their integration, testing, and commissioning processes. Additionally, you'll find valuable guidance, ensuring that your team is well-prepared to maximize the sensor's capabilities effectively. This section serves as a hands-on guide to put our technology to work in your environment.

6.1 Preparation

Prior to initiating the installation procedure, it is crucial to ensure that you have all the essential materials and devices readily available.

Devices Needed

- K-Detect-iON

Tools Needed

- Modbus cables
- Screw driver
- Screws, bolts and nuts - for mounting purposes

Things to check

- Ensure that there is no visible damage on any of the devices
- Check the functionality of all network cables and ensure that they are free from any defects that could affect the quality of results.
- Prepare the location or area where you intend to place or install the devices.

Adhering to these guidelines will contribute to a successful and trouble-free installation process.

6.2 Mounting Installation Guidelines

Our sensors offer flexible mounting solutions, providing you with various options for installation:

Important Note:

To ensure proper safety and functionality, the unit must be grounded to an earth ground during installation. Connect the grounding wire to one of the enclosure mounting holes, using a screw and washer to secure it firmly and provide a reliable connection. Proper grounding is essential for Electrostatic Discharge (ESD) protection and optimal device performance. Ensure the connection complies with local electrical and safety codes and test it before powering the unit.

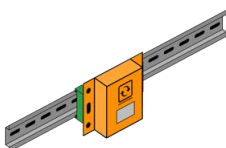

DIN Rail: Ideal for secure, space efficient mounting with compatible enclosures or control panels.

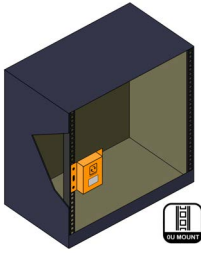

0U Rack: Allows for efficient and organized rack-based installation, conserving valuable rack space.

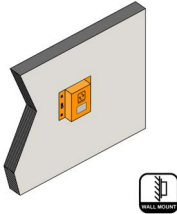

Wall Mount: Perfect for affixing units to walls, optimizing placement within your environment.

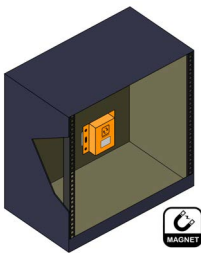

Magnetic: Offers to convenience of magnetic attachment, making it easy to position the components as needed.

Section 7

Setting Up

7.1 Securing Wires in Screwless Terminal Blocks

1. Push and hold the orange tab.

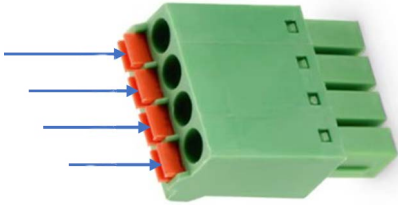

You may use your finger or you may also use a precision flat screwdriver to perform this action (as shown the image below). This action opens the contact, creating space for the wire.

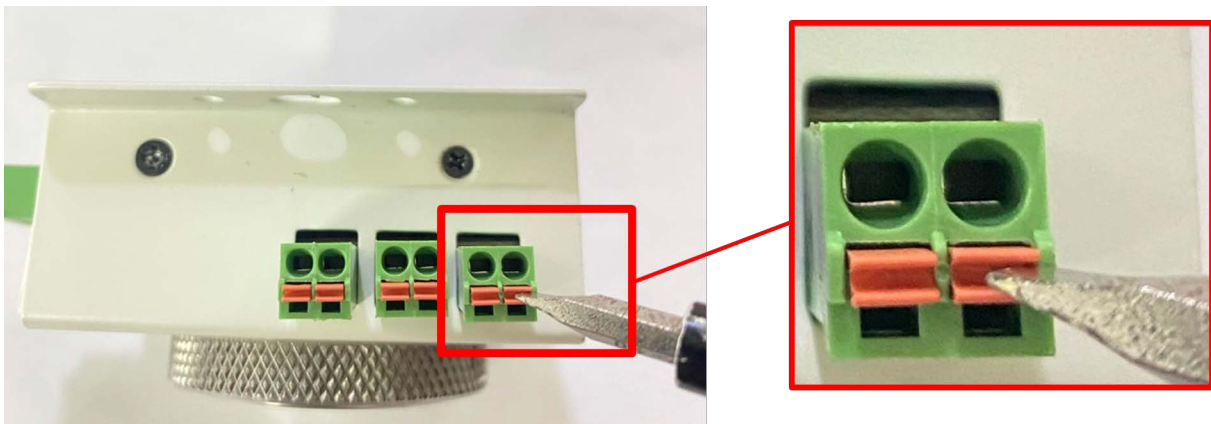

Note: Push the orange tab towards the terminal

2. While pushing and holding the orange tab, fully insert the stripped end of the wire into the terminal block. Ensure the wire is properly stripped and aligned. You may use a solid wire with a gauge ranging from 16 to 24 AWG for optimal compatibility.

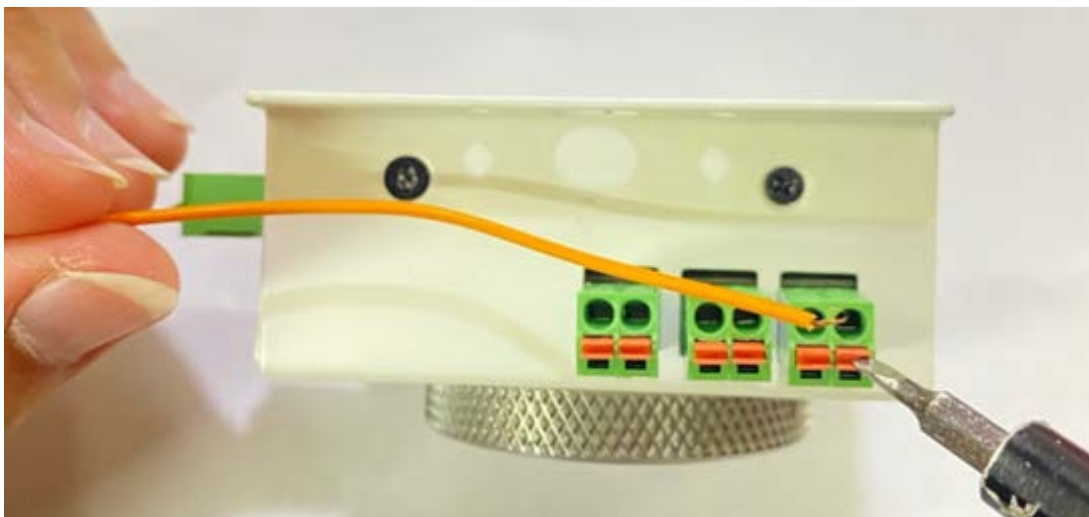

3. Release the orange tab. The spring will secure the wire in place, ensuring a firm connection.

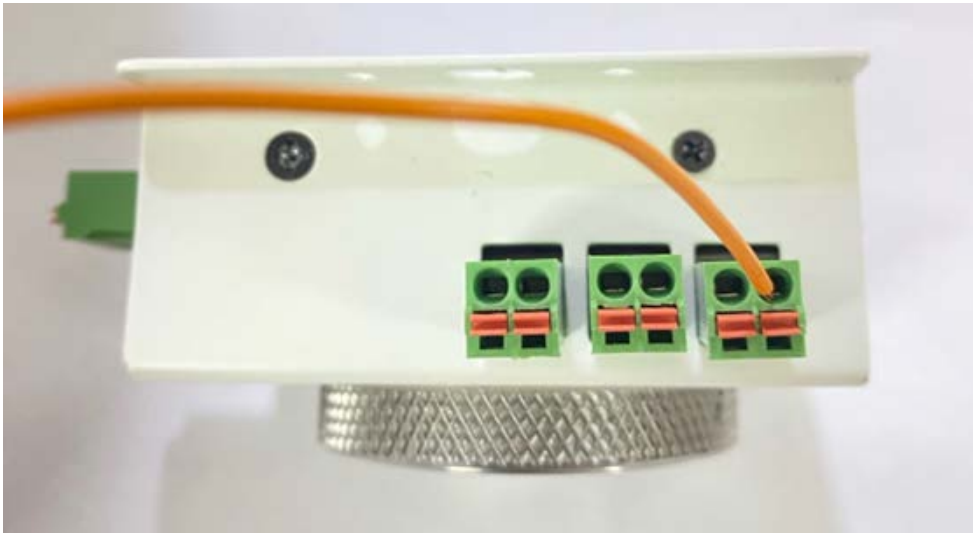

4. Gently tug on the wire to confirm if it is securely held within the terminal block.

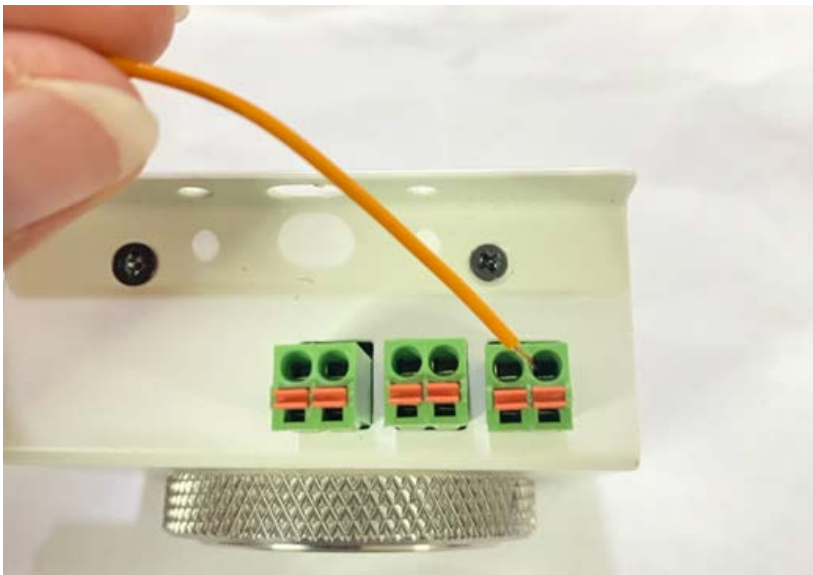

7.2 Powering up the K-Detect-iON

The K-Detect-iON sensor introduces a versatile power-on mechanism with two distinct options. The primary method involves powering the sensor through a direct current (DC) source, accommodating voltages within the range of 12 to 24 volts. This feature ensures compatibility with a variety of DC power systems commonly employed in industrial settings, providing users with a reliable and standard power option for seamless integration into existing infrastructures.

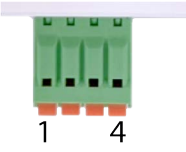
	<p>Terminal Block – This block comprises terminals for various connections:</p> <ul style="list-style-type: none"> • Terminal 1: 12 to 24V DC power input • Terminal 4: Ground (GND) <p>Note: Please refer to section 7.1 when inserting wires into the terminal block</p>
---	--

Important Note:
 The device requires a minimum warm-up period of 2 days in a clean environment to ensure accurate readings. It is crucial to allow the sensor to complete this warm-up period before relying on its readings for precise and reliable information. After the warm-up period, perform a power cycle to ensure the device operates optimally and provides accurate data.

7.3 Standalone RS485 Connection (Modbus)

Below is the wiring configuration for the terminal block, that connects the sensor to your desired platform via RS485.

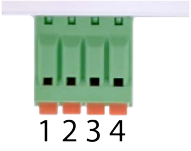
	<p>Terminal Block – This block comprises terminals for various connections:</p> <ul style="list-style-type: none"> • Terminal 1: 12 to 24V DC power input • Terminal 2: (B-) Connection • Terminal 3: (A+) Connection • Terminal 4: Ground (GND) <p>Note: Please refer to section 7.1 when inserting wires into the terminal block</p>
---	--

To set up the Slave ID address please refer to the image below. Please note that there is a pointer which corresponds to the value that it is set to.



Example:

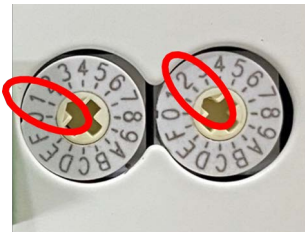

Important Note: The combination of 0 and 0 or F and F are not functional. Please ensure these configurations are avoided to maintain proper operations.

7.3.1 Default Modbus Connection Settings

As a standalone device below are the default thresholds and configurations.

Parity	None
Baud rate	1200
Stop bit	1

7.3.2 Default Relay Threshold

The relay is triggered based on the flammable gas reading, with the threshold determined by the value of the gas sensor expressed in percentage Lower Explosive Limit (%LEL).

For newly purchased sensors, the default settings assign Relay A and B threshold values to CH₄, and Relay C to the Fault relay. However, you can customize or adjust both the sensor type and the threshold values to trigger each relay, using the Modbus table in Section 7.4 as a reference.

Relay A	25% LEL
Relay B	10% LEL
Relay C	Fault Relay

7.3.3 Default Relay State

The default relay state refers to the initial or resting position of a relay when no external power or signal is applied. This state is typically either normally open (NO) or normally closed (NC), indicating whether the relay allows or interrupts the electrical circuit by default. A power cycle is required after applying any changes or updates.

Normally Open	00
Normally Closed	01

7.3.4 Relay Delay

Relay delay is the intentional time interval between the activation signal and the actual switching action of the relay.

7.3.5 Relay Minimum Running Time

Relay minimum running time refers to the minimum duration the relay remains active starting from the moment it is triggered.

Once the threshold is reached, the relay will continue to operate until it is manually turned off.	-1
After the threshold is reached, the relay will turn off immediately once the conditions return to normal.	00
The relay will activate once the threshold is reached and will continue running for a minimum of XX seconds. For example, if you set the running time to 30 seconds but the conditions have not returned to normal, the relay will keep running until the conditions normalize.	XX seconds

7.4 Modbus Table

Modbus Register Address	Description	Register Type	Data Type	Information		
				Decimal	Binary	Status
30001	Sensor Status	Read-Only	u16	0	0	OK
				1	1	Warm up (2 min) VOC Fault
				2	10	Temp/Hum Fault
				4	100	Gas sensor fault
				8	1000	CH ₄ sensor fault
				16	10000	CH ₄ sensor out of sync
				64	1000000	EOL (End of Life)
				Other values	Combination	Multiple status (sum of values)
				30002 to 30003	VOC Reading	Read-Only
30004 to 30005	H ₂ Reading	Read-Only	32-bit Float (Little Endian Byte Swap)			
30006 to 30007	Internal Temperature Reading	Read-Only	32-bit Float (Little Endian Byte Swap)			
30008 to 30009	Internal Humidity Reading	Read-Only	32-bit Float (Little Endian Byte Swap)			
30010 to 30011	CH ₄ Reading	Read-Only	32-bit Float (Little Endian Byte Swap)			
30013 to 30014	Other Flammable Gas	Read-Only	32-bit Float (Little Endian Byte Swap)	In %LEL		
30016 to 30017	H ₂ mixture	Read-Only	32-bit Float (Little Endian Byte Swap)	In % LEL		
40001	Modbus Address	Read-Only	u16			
40002	Parity Bit	Read-Write	u16	0 = None, 1 = Odd, 2 = Even		
40003	Baud rate	Read-Write	u16	0 = 1200, 1 = 2400, 2 = 4800, 3 = 9600, 4 = 19200, 5 = 38400		
40004	Stop Bits	Read-Write	u16	0 = 1.5, 1 = 1, 2 = 2		
40005	Relay A Threshold	Read-Write	u16	This is where you set the value to trigger the relay based on the sensor you chose on address 40026		
40006	Relay B Threshold	Read-Write	u16	This is where you set the value to trigger the relay based on the sensor you chose on address 40027		
40007	Relay A Default State	Read-Write	u8	0 = Normally Open, 1 = Normally Close		

Modbus Register Address	Description	Register Type	Data Type	Information
40008	Relay B Default State	Read-Write	u8	0 = Normally Open, 1 = Normally Close
40009	Relay A Delay	Read-Write	u16	In Seconds
40010	Relay A min. running time	Read-Write	u16	In seconds; -1 No end 00 – right away
40011	Relay B Delay	Read-Write	u16	In Seconds
40012	Relay B min. running time	Read-Write	u16	In seconds; -1 No end 00 – right away
40022	Relay C Threshold	Read-Write	u16	This is where you set the value to trigger the relay based on the sensor you chose on address 40028
40023	Relay C Default State	Read-Write	u8	0 = Normally Open, 1 = Normally Close
40024	Relay C Delay	Read-Write	u16	In Seconds
40025	Relay C min. running time	Read-Write	u16	In seconds; -1 No end 00 – right away
40026	Relay A Trigger Source	Read-Write	u8	0 = H ₂ ; 1 = Temp; 2 = Hum; 3 = VOC; 4 (Default) = CH ₄ ; 5 = Direct control; 6 = Fault Relay; 7 = any gas (H ₂ , CH ₄ and diff gas concentration); 8 = H ₂ mixture
40027	Relay B Trigger Source	Read-Write	u8	0 = H ₂ ; 1 = Temp; 2 = Hum; 3 = VOC; 4 (Default) = CH ₄ ; 5 = Direct control; 6 = Fault Relay; 7 = any gas (H ₂ , CH ₄ and diff gas concentration); 8 = H ₂ mixture
40028	Relay C Trigger Source	Read-Write	u8	0 = H ₂ ; 1 = Temp; 2 = Hum; 3 = VOC; 4 (Default) = CH ₄ ; 5 = Direct control; 6 = Fault Relay; 7 = any gas (H ₂ , CH ₄ and diff gas concentration); 8 = H ₂ mixture
40041	Relay Status	Read-Only	u16	Bit 0 (right most) = Relay 1, Bit 1 = Relay 2, Bit 2 = Relay 3
1	Relay A	Read-Write		Relay A Status (Optional Trigger to test Relay ON/OFF)
2	Relay B	Read-Write		Relay B Status (Optional Trigger to test Relay ON/OFF)
3	Relay C	Read-Write		Relay C Status (Optional Trigger to test Relay ON/OFF)

NOTE: To apply changes to the Modbus connection settings, please refer to the following. Note that these changes are only applicable to the following Modbus register addresses (40002, 40003, 40004, 4007, 4008 and 40023).

If you customize the Parity, Baud Rate, or Stop Bits settings, these will need to be set up again. Additionally, a reboot is required if changes are made to the Parity, Baud Rate, or Relay Default State.

The 40041 register represents the relay status using a bitwise value system, where each relay is assigned a specific value equivalent to Relay 1 = 1, Relay 2 = 2, and Relay 3 = 4. When a relay is energized, its corresponding value is added to the total displayed in the Modbus register. For example, a value of 5 (1 + 4) displayed on the register indicates that Relay 1 and Relay 3 are energized, same with the value of 6 (2 + 4) signifies that Relay 2 and Relay 3 are energized.

7.5 Connecting K-Detect-iON to Fire Alarm

When connecting the K-Detect-iON sensor to two fire alarm wires in a terminal block for a series connection, follow these crimping steps:

1. Prepare the wires:

- Strip the insulation from the ends of the two fire alarm wires to expose the copper conductors. Ensure both wires have the same stripped length for a secure connection.

2. Insert into the Ferrule:

- Take a 16-24 AWG ferrule connector and insert both stripped wire ends into it. Ensure that the wires are fully inserted and aligned properly within the ferrule.

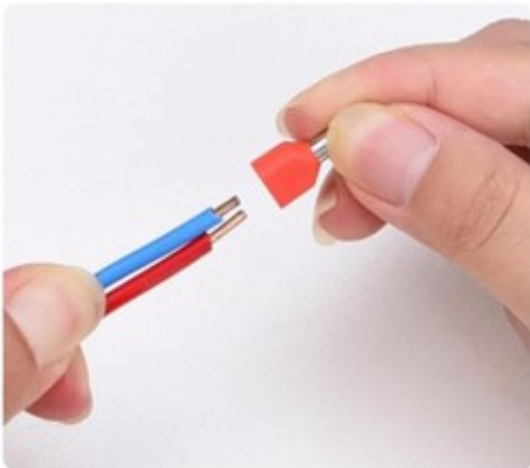

3. Crimp the Ferrule:

- Place the ferrule into the crimping tool, aligning it within the correct slot. Squeeze the crimping tool firmly to secure the connection. The ferrule should now hold both wires tightly.



4. Verify the Crimped Connection:

- Check the crimped ferrule to ensure a secure and solid connection, The wires should not be loose or able to slip out.



5. Connect to the Terminal Block:

- Insert the crimped ferrule into the designated terminal block for the K-Detect-iON sensor.
- For detailed instructions on properly securing the ferrule in the terminal block, please refer to Section 7.1, which provides step-by-step guidance to ensure a secure and reliable connection.

Section 8

Testing

8.1 Periodic Bump Testing of Sensors

To confirm proper operation and ensure full integration with safety and other systems, periodic bump testing of sensors shall be performed. In the absence of specific code requirements specifying the testing interval, it is recommended to conduct bump testing at least annually out of an abundance of caution. This testing may be conveniently carried out during scheduled fire safety inspections.

Additionally, bump testing shall be performed during the initial setup of the system.

For gas calibration, we typically source cylinders through [Calgas](https://www.calgas.com) and for the gas regulator, we utilize a 2.5 LPM regulator from Calgas <https://www.calgas.com/6c10>

Required equipment:

- Gas sensor
- Gas Bump Adapter (AX-GAS-BUMP)
- Gas tubing (from your local gas supplier)
- Gas valve regulator (300ml/min)
- Gas cannister

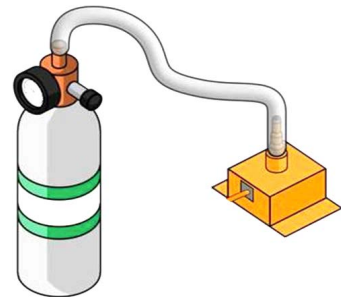

Procedure:

1. Prepare Workspace:

- Ensure proper ventilation in the testing area.

2. Prepare the sensor:

- Remove the gas cap from the sensor by rotating it counter clockwise.
- Replace it with the gas bump adapter, rotating it clockwise until secure.

3. Connect tubing:

- After securely attaching the gas bump adapter to the gas sensor, connect one end of the gas tubing to the adapter, and the other end to the gas cannister.
- Finally, connect the gas sensor to the controller and wait until warm up time is finish.

4. Secure Gas Cylinder:

- Ensure that the gas cylinder is securely mounted and in a stable position.

5. Perform the Bump Test:

- Gradually open the cylinder valve to ensure a controlled flow of gas to the sensor. Do not fully open the valve; only open it enough to allow the gas to flow.
- Let the gas flow until the sensor detects it.
- Monitor the sensor readings on your monitoring device.

6. Stop Gas Flow:

- Close the cylinder valve to stop the flow of gas.

7. Verify the Sensor Response:

- Check the sensor readings. The values should respond to the gas exposure.
- Ensure that the sensor triggers an alert if configured to do so.
- (Please refer to section 8.4 Testing via Modbus)

8. Maintenance:

- If the sensor passes the bump test, consider it operational.
- If any issues are identified via the status register during the test, make sure to note what error or value is showing before contacting the manufacturer.

8.2 Bump & Calibration gases for CH₄

It is recommended to use synthetic air containing approximately 20% VOL oxygen, simulating the conditions of a typical natural environment. It is also recommended to preheat for 7 days or at least 2 days prior in doing the bump testing. While there is no specified gas flow rate, it is advised to maintain a low flow rate, gradually open the cylinder valve to ensure a controlled flow of gas to the sensor. Do not fully open the valve; only open it enough to allow the gas to flow to ensure optimal sensor performance.

CH₄ Gas Cylinder: 50% LEL - 17L steel (Compatible with 6000 Series Multiflow)

<https://www.calgas.co/biosystems-54-9079-equivalent>

Important note: Results might differ when using target gas mixed with other gases.

8.3 Bump & Calibration gases for H₂ & other flammable gas detection

To ensure accurate testing, the background gas should remain consistent throughout the procedure by using zero air or the recommended gas mixtures outlined in the table below. The suggested flow rate for the gas valve regulator is 300 mL/min. Refer to the table below for the recommended gas cylinder mixtures suitable for bump testing.

H₂ Gas Cylinder: 50% LEL - 34L steel (Compatible with 6000 Series Multiflow)

<https://www.calgas.co/50lel-hydrogen-34l>

Important note: Results might differ when using target gas mixed with other gases.

	Nitrogen	Oxygen	Argon	CO ₂	Flammable Gas	H ₂ S	CO
"Quad Mix" with 50% LEL (ISO) methane	Balance	0.18	0	0	0.025	25 PPM	100 PPM
"Quad Mix" with 50% LEL (IEC) methane	Balance	0.18	0	0	0.022	25 PPM	100 PPM

	Nitrogen	Oxygen	Argon	CO ₂	Flammable Gas
Synthetic (dry) air at 50% LEL (ISO) methane	0.7613	0.2043	0.0091	0.0004	0.025
Synthetic (dry) air at 50% LEL (IEC) methane	0.7636	0.2049	0.0091	0.0004	0.022
Synthetic (dry) air at 50% LEL (ISO) pentane	0.7749	0.2079	0.0092	0.0004	0.0075

	Zero air	Flammable gas
50% LEL (ISO) methane	Balance	0.025
50% LEL (IEC) methane	Balance	0.025

8.4 Testing via Modbus

It is advisable to conduct regular assessments of the gas sensor's performance in critical environments. It plays a crucial role in ensuring the dependability, functionality, and security of systems utilizing Modbus communication.

Testing a device via Modbus involves using Modbus commands to read or write data from/to device's registers.

Here's a general guide on how to perform Modbus testing manually:

Requirements:

- Modbus Master Device or Software

Use a Modbus master device or software to send commands and receive responses.

Popular Modbus master software includes Modbus Poll, QMod Master, or any other Modbus testing tool.

- K-Detect-iON

Procedure:

1. Identify device registers:

- In order to identify the device registers, check the Modbus Table in section 7.4 to find the specific registers you need to read or write. These registers store important data like sensor reading, device status, or control information.

2. Confirm Modbus device address:

- Every device on a Modbus network has its own unique address. Make sure you know the address of the device you're working with.

3. Check communication settings:

- Please refer to section 7.3.1 to 7.4 to find out the communication settings your device uses, like the baud rate, stop bits, and parity.
- Next step: Set your Modbus master device or software to use the same settings.

4. Connect the Modbus Master:

- Physically connect your Modbus master (e.g., computer or controller) to the sensor via terminal block. Please refer to the image below for reference:

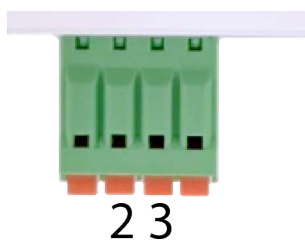

Terminal Block – This block comprises terminals for various connections:

- Terminal 2: (B-) Connection
- Terminal 3: (A+) Connection

Note: Please refer to section 7.1 when inserting wires into the terminal block

5. Launch Modbus master software:

- Launch your Modbus master software on your computer and create a new connection to the sensor.

6. Configure Connection:

- Enter the communication parameters (Baud rate, parity, stop bit) in the Modbus master software to establish a connection.
- For establishing communication between the sensor and the Modbus master, set a unique slave ID by adjusting the rotary encoder according to your preference.



- Once the Slave ID is assigned, enter this designated ID into your Modbus Master configuration to establish communication between the sensor and the Modbus Master.
- Note: The Slave ID on the rotary as showed on the example on section 7.3 is set to hexadecimal.
- Next, identify the Modbus register address of the sensor you want to check. For example, if you're checking the VOC sensor, its address is 30002. Once you have the correct address, enter it into your Modbus master software along with the quantity and scan rate. After configuring these settings, confirm or apply them.
- To retrieve the current sensor value, ensure that you also input the correct data type for the sensor. Once all settings are applied, you will be able to view the real-time sensor values in your Modbus master software.

7. Identify Relay Register:

- Determine the Modbus register address associated with the relay you want to trigger on the Modbus Slave device.
- For example, the Modbus register address will be 40007 if you wanted to trigger the Relay A. Please see section 7.4 for reference.
- Note: Check if it's a discrete input, coil, or holding register. (these are just different types of data).

8. Write the Modbus Command:

- In the Modbus master software – find the function code for writing to a discrete output (this allows you to control device like relays).
- Enter the Modbus Slave ID, register address, and the command value (the value that will trigger the relay).

9. Send Modbus Command:

- Trigger the relay by sending the configured Modbus command from the Modbus Master to the Modbus Slave device.
- Monitor the response from the Modbus Slave to ensure successful relay triggering.

10. Verify the Relay State:

- Check the physical state of the relay on the Modbus Slave device to confirm that it has been triggered.

11. Triggering Relay using gas bump test:

- Identify the sensor value you wish to test during the gas bump procedure. For more details, refer to number 6.
- Once you've identified the sensor, assign it to one of the relays. For example, assign H₂ to Relay A threshold. In the Relay A threshold setting, enter 0, since H₂ = 0. (please see Modbus table in section 7.4 for reference)
- In Modbus address 40005, which corresponds to Relay A's threshold, enter your desired value. For this example, set the threshold to 10% LEL
- Apply the gas from your cannister to the sensor (refer to Section 8.1 for gas bump testing). Observe if the H₂ value increases, indicating a successful bump test. When the value exceeds the set threshold, such as 10% LEL, Relay A will be triggered.